

Tiratutto

TIRATUTTO



LINEA HOBBY / FAI DA TE
HOBBY AND D.I.V. RANGE
GAMME LE LOISIR
HOBBYSERIE
LÍNEA DE BRICOLAJE

IMPORTANTE: IL PRODOTTO NON PUO' ESSERE UTILIZZATO IN SERVIZIO CONTINUO (classe di sollevamento A2)
IMPORTANT: THE PRODUCT CAN'T BE USED IN CONTINUOUS SERVICE (lifting class A2)
IMPORTANT: LE PRODUIT NE PAS PEUT ÊTRE UTILISÉ EN SERVICE CONTINUU (classe de levage A2)
WICHTIG: DAS PRODUKT KANN NICHT IM DAUERBETRIEB ANGEWENDET WERDEN (Hebevorrichtung Klasse A2)
IMPORTANTE: EL PRODUCTO NO PUEDE SER UTILIZADO EN SERVICIO CONTINUADO (clase de elevamiento A2)



VERSIONI - VERSIONS - MODÈLES - AUSFÜHRUNGEN - VERSIONES

TIRATUTTO 125TS Cod. TT125S12T0

TIRATUTTO 200TS Cod. TT200S18T0

TIRATUTTO 125TD Cod. TT125S12T1

TIRATUTTO 200TD Cod. TT200S18T1

ACCESSORI - ACCESSORIES - ACCESSOIRES - ZUBEHÖR - ACCESORIOS



125/200 Kg cod. ATTTDC0010

200/400 Kg cod. ATTTDC0020

CARRUCOLA TIRO DOPPIO

DOUBLE-THROW PULLEY

POULE À DOUBLE TIR

DOPPELZUGROLLE

POLEA DE DOBLE TIRO

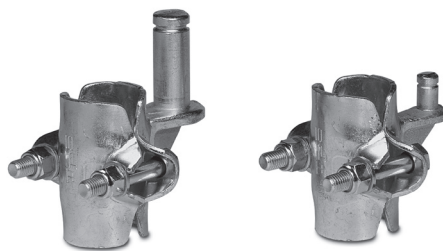

cod. AHTPTA0030

COPPIA MORSETTI

CLAMP COUPLE

PAIRE DES COLLIERES

KLEMME PAAR

PAREJA MORDAZA

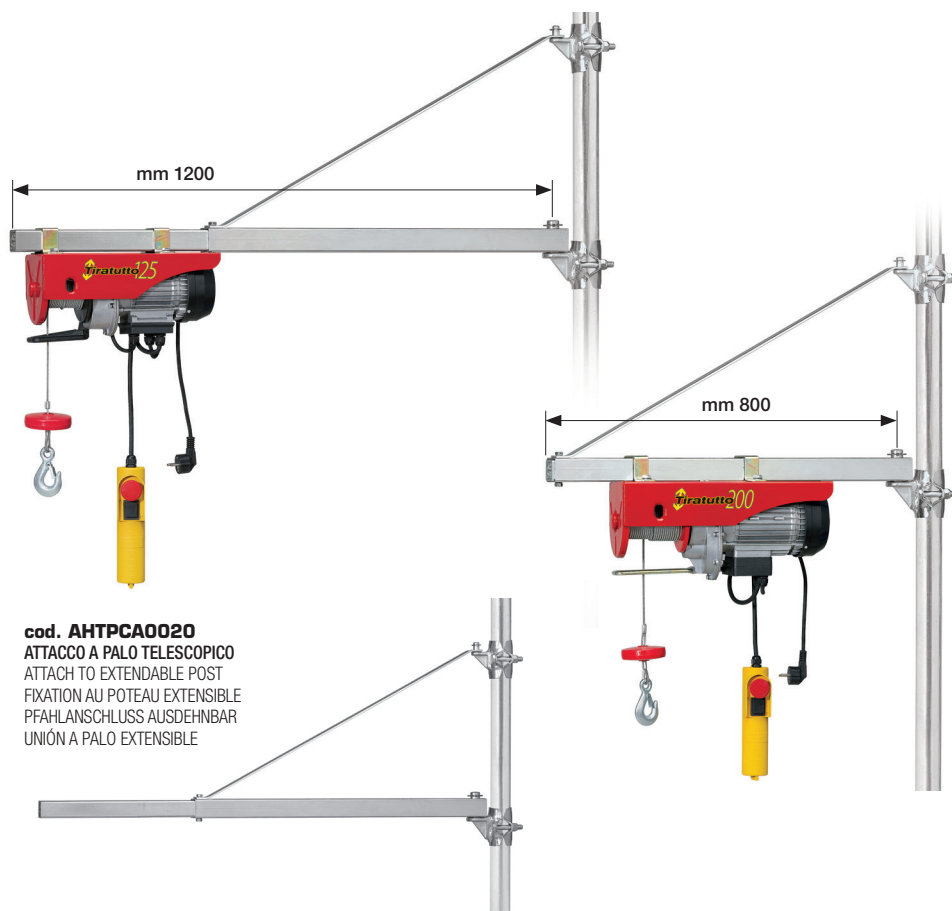

cod. AHTPCA0020

ATTACCO A PALO TELESCOPICO

ATTACH TO EXTENDABLE POST

FIXATION AU POTEAU EXTENSIBLE

PFAHLANSCHLUSS AUSDEHNBAR

UNIÓN A PALO EXTENSIBLE

MODELLO - MODEL - MODÈLE - MODELL - MODELO

TIRATUTTO 125

TIRATUTTO 200

TIPO MOTORE - MOTOR TYPE - TYPE DU MOTEUR - MOTOR TYP - TIPO MOTOR

MONOFASE
MONOPHASE
EINPHASEN - MONOFÁSICO

Trifase
Threephase - Triphasé
Dreiphasen - Trifásico

TENSIONE - VOLTAGE - TENSION - SPANNUNG - TENSION

230 V

230 V

FREQUENZA - FREQUENCY - FRÉQUENCE - FREQUENZ - FRECUENCIA

50 Hz

50 Hz

PORTATA MAX. - MAX. LIFTING CAPACITY - CHARGE MAX. - LAST MAX. - CAPACIDAD

100 KG T.S.
200 KG T.D.

200 KG T.S.
400 KG T.D.

POTENZA MOTORE - ENGINE POWER - PUISSANCE DU MOTEUR - LEISTUNGS-AUFNAHME - POTENCIA MOTOR

450 W

750 W

VELOCITÀ DI SALITA - LIFTING SPEED - VITESSE DE LEVAGE - AUFSTIEGSGESCHWINDIGKEIT - VELOCIDAD DE ELEVACIÓN

10 M/MIN T.S.
5 M/MIN T.D.

10 M/MIN T.S.
5 M/MIN T.D.

TIRO UTILE - CABLE LENGTH - CHARGE UTILE - ARBEITSHÖHE/SEILLÄNGE - ALTURA DE ELEVACIÓN

11 M T.S.
5,5 M T.D.

18 M T.S.
9 M T.D.

DIAMETRO FUNE - STEEL CABLE DIAMETER - DIAMÈTRE DU CÂBLE - SEILDURCHMESSER - DIAMETRO DEL CABLE

3 MM

4 MM

CARICO ROTTURA FUNE - CABLE BREAKING POINT UNDER LOAD - CHARGE DE RUPTURE DU CÂBLE
BRUCHLAST DES SEILS - CARGA DE ROTURA DEL CABLE

>1200 KG

>1600 KG

PESO ELEVATORE - HOIST WEIGHT - POIDS DU TREUIL - GEWICHT - PESO

11 KG

16 KG